

HDG Pelletmaster 15  
HDG Pelletmaster 25



**HDG Bavaria**

Heating systems for wood

Products  
from Bavaria  
Germany

## Pellet heating system



DISTRIBUTED BY



ENERGY

**Glas**

Mullins Mill  
Kells, Co. Kilkenny  
Ireland  
Tel: +353 (0)56 7728255  
or freephone  
1800 ENERGY (363749)  
info@glas.ie  
www.glas.ie



*Heating with wood*  
convenient  
and innovative

# Heating with pellets

## What makes heating with pellets so attractive?

### ■ environmentally friendly

Heating with wood pellets does not contribute to climate change. Wood Pellets are regarded as carbon neutral. When pellets are burned they release solar energy absorbed during the trees growth. The CO<sub>2</sub> released in this process is equal to the CO<sub>2</sub> absorbed during the trees growth. In addition, localised production of wood pellets dramatically reduces transport related emissions. Wood pellets not only save energy in terms of manufacturing and delivery, but also create local employment opportunities. They are an important contribution to a sustainable future for our children.

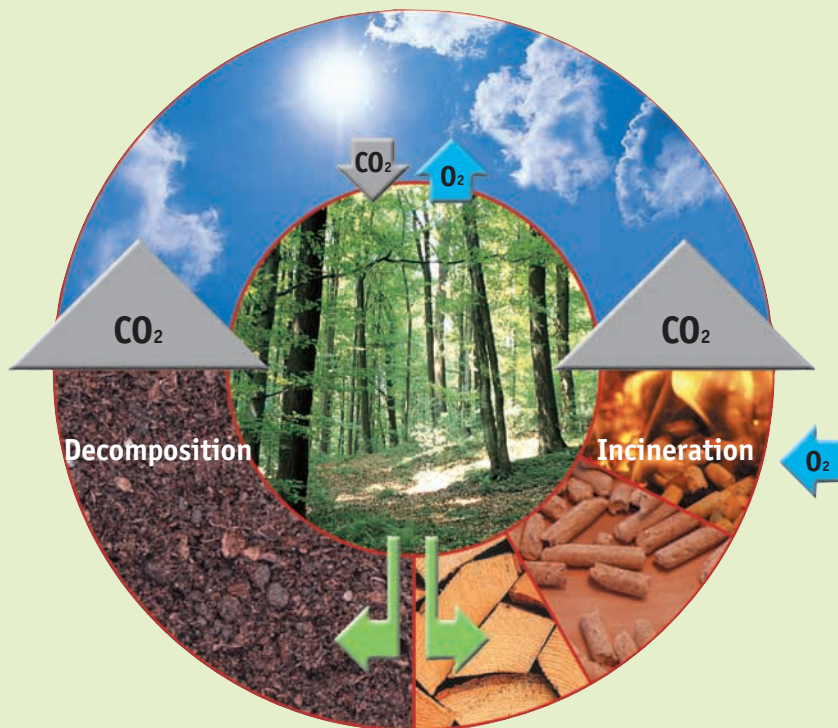

### ■ economical and crisis-proof

In terms of energy cost, pellets compare favourably with other fuels. Economical and political trends indicate that fossil fuels (oil and gas) will become increasingly expensive in the future.



## What are pellets?

Pellets are made of 100 % natural wood. The bulk of the raw material comes from our domestic wood processing industry. The shavings and sawdust are compressed under high pressure and pressed into small cylindrical rolls and held together by lignin, contained naturally in the wood. This results in a clean, convenient fuel with a high calorific value and very low ash content (0.2%). All of these facts are what makes the most convenient of all wood fuels such an interesting alternative in terms of both ecology and economy.

2 kg pellets	≈ 1 l fuel oil
650 kg pellets	= 1 m <sup>3</sup>
1 kg pellets	= 4.9 kWh

For current subsidies visit:

[www.hdg-bavaria.com](http://www.hdg-bavaria.com)

# The HDG Pelletmaster – a true master

What is special about the HDG Pelletmaster?

HDG has specialized in wood-fired heating for almost 25 years.

The HDG Pelletmaster incorporates innovation, with tried and tested experience.

Take advantage of the convenience of pellet heating, combined with the proven quality, strength and durability of HDG products.

## The advantages of the HDG Pelletmaster:

### ■ especially clean

The advanced combustion technology of the pelletmaster is perfectly designed to burn pellets as a fuel, resulting in very low emission values. Extremely high efficiency levels are also achieved through the combustion of this environmentally friendly fuel.

### ■ especially economical

Optimised combustion technology results in low pellet consumption. An advanced thermostat controls the boiler temperature ensuring that only the required amount of heat is produced.

### ■ absolutely safe

The HDG Pelletmaster has been subjected to strict in-house and independent safety tests. The cellular wheel sluice reliably prevents back-burn and the escape of low temperature gas. This sluice wheel, combined with an integrated water extinguishing system provides total safety.

### ■ especially convenient

Features such as automatic transport of the pellets to the combustion chamber, automatic ignition, self activated cleaning and large ash container combine to provide maximum convenience automatically controlled by the HDG Pelletronic boiler control.

### ■ awards for innovation and design

The HDG Pelletmaster was awarded the "KWF Innovation Prize" by the Committee for Forest Labour and Forest Engineering. The unique shape has been distinguished with the "iF design award 2004" and was nominated by the Federal Ministry for Economy and Labour for the "Design Prize of the Federal Republic of Germany 2004".



## We will be pleased to provide individual assistance!

It is not only boiler efficiency and emissions values that are decisive for an economical, convenient and ecological heating system.

It is just as important for your heating specialist – trained by us – to determine your individual requirements, taking your preferences into account. All components that you wish to integrate in your heating system will be optimally integrated and controlled.

# The mechanical integrity of the HDG Pelletmaster

The engineering innovations of the HDG Pelletmaster for maximum quality and reliability:

- Automatic cleaning of the heat exchanger surfaces
- Tried and tested step grate technology prevents the formation of slag; The grate movement provides for automatic ash clearing into a removable container. Automatic ignition via hot air blowers provides for an efficient, short ignition phase and fast heating up to the operating temperature
- The pellet management system has been designed to ensure minimum wear and energy expenditure.
- Unique combustion and performance control due to the combination of combustion chamber temperature sensor and Lambda sensor, giving a system that is emission and performance-coordinated
- The Lambda sensor is mounted in a protected position, the longest life possible
- A precision designed cellular wheel sluice, together with existing pressure compensation reliably prevents back-burn and escape of low-temperature gas

## Cutaway view of HDG Pelletmaster

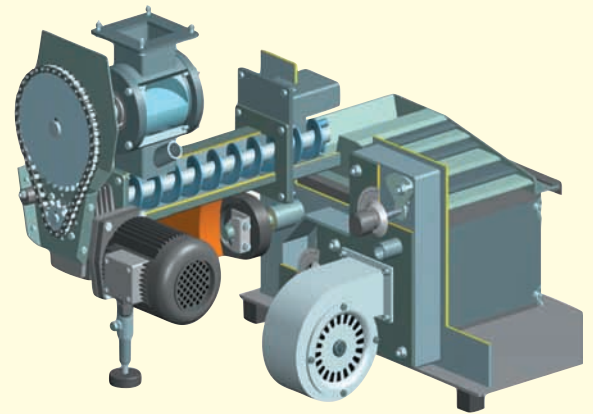
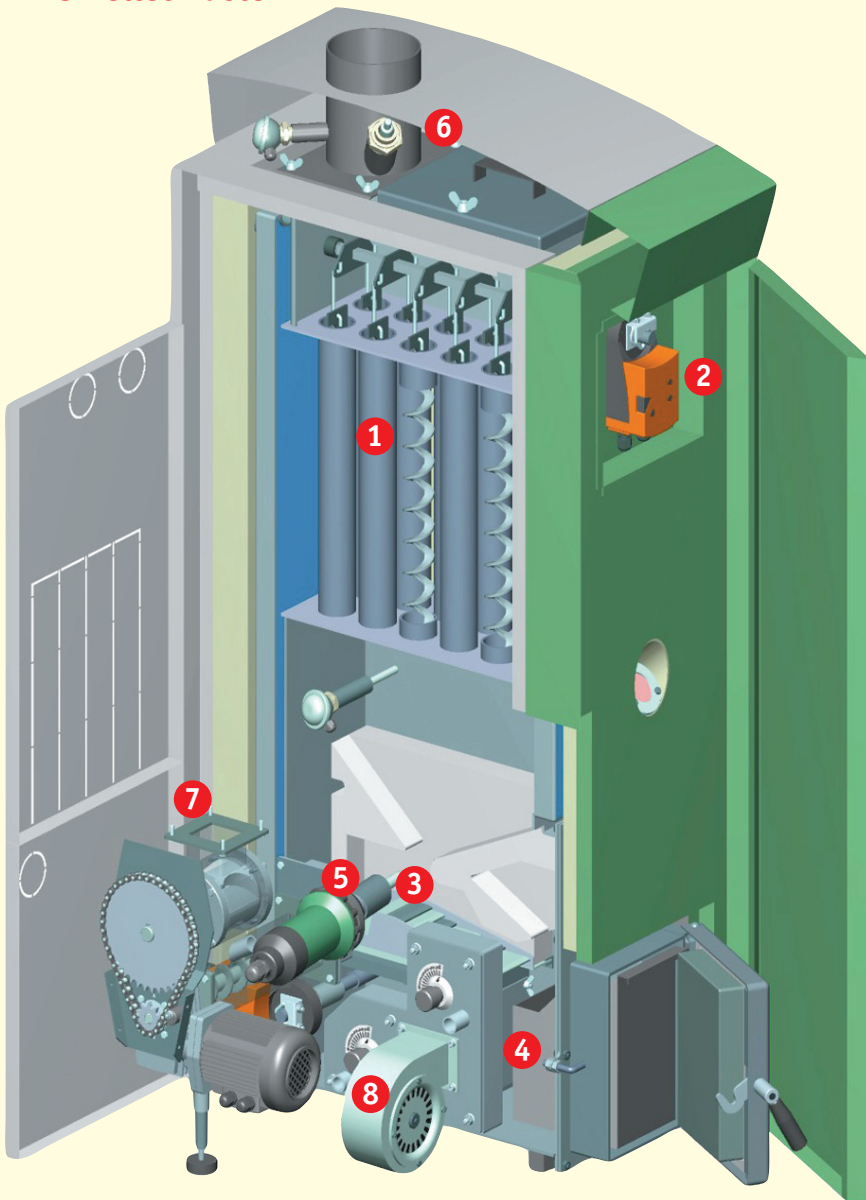

Detail of step grate

### Legend

- ① heat exchanger surfaces
- ② automatic cleaning
- ③ unique step grate
- ④ ash container
- ⑤ automatic ignition
- ⑥ lambda sensor
- ⑦ cellular wheel sluice
- ⑧ combustion blower

# HDG Pelletronic® – System control

## Everything under control:

- Microprocessor control with user-friendly operator controls and display
- Monitoring of the return flow temperature to prevent damage from corrosion
- On demand and outdoor temperature control of the boiler output
- Extended boiler life due to automatic protection program (boiler ventilation for corrosion protection, protective function for Lambda sensor and anti-seize protection program for components)
- Integrated accumulator management prevents unnecessary startup and cooling phases



HDG Pelletronic



## The technical data for the HDG Pelletronic

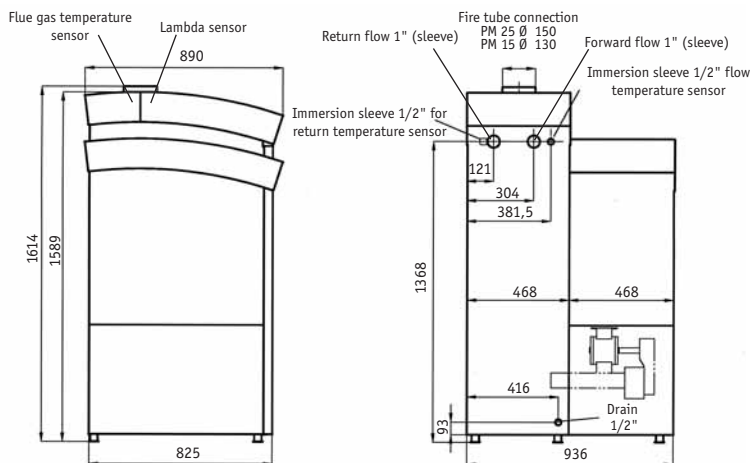

Installation dimensions without covering 370 x 790 x 1450 mm

System type	HDG PM 15	HDG PM 25
Nominal thermal output	15 kW	25 kW
Minimum thermal output	4.5 kW	7.5 kW
Boiler temperature	65 - 90 °C	65 - 90 °C
Max. operating pressure	3 bar	3 bar
Required delivery pressure	15 Pa	15 Pa
Water content	100 l	100 l
Weight	288 kg	288 kg
Electrical connection	230 AC; 50 Hz	230 AC; 50 Hz
Chimney connection	130 mm	150 mm

# The pellet storage area

The right storage capacity for pellets is easy to achieve.  
Your heating installer will calculate the exact fuel requirement.

**Rule of thumb: 1 kW heating load = 0.9 m<sup>3</sup> storage space**

- The HDG suction conveyor system is suitable for storage that is far from the heater area (e.g. in renovated older buildings) or also for pellets stored in underground tanks or sack silos.  
We will be pleased to provide further information on optimising your storage methods.

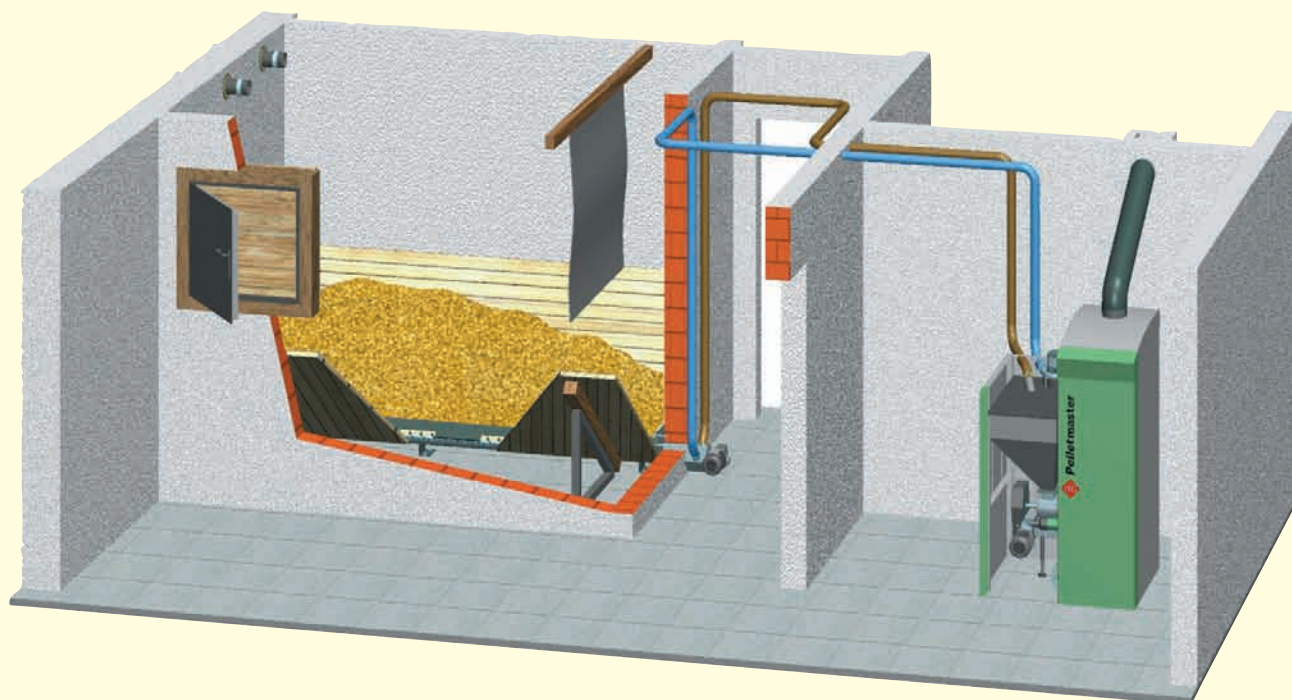

Example of a purpose-built pellet storage area in combination with the HDG suction system

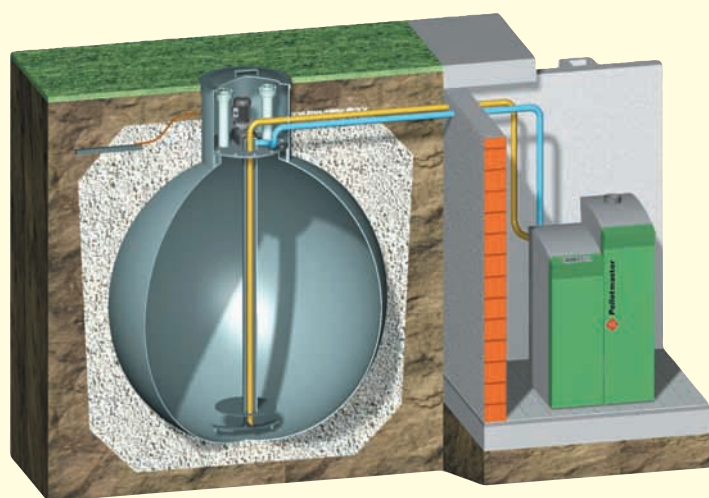

Example of underground pellet storage in a buried tank.

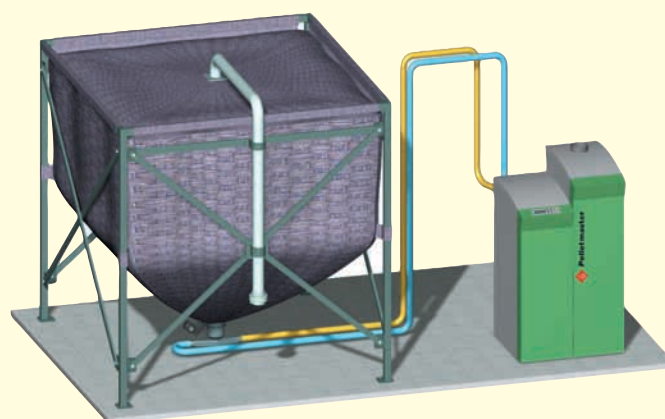

Example for pellet storage in sack silo.

# HDG Hydronic – the heater control

Modern heating systems are made up of various components. The Hydronic controls all components of your heating system as an add-on module to your HDG Pelletmaster. It ensures the correct and environmentally compatible operation of your complete heating system.

Hydraulic solutions are available for every application. Here we see an example of an HDG heating system with an accumulator, household water tank, solar collectors and two heating circuits. Your local specialist will be glad to provide with individual assistance.

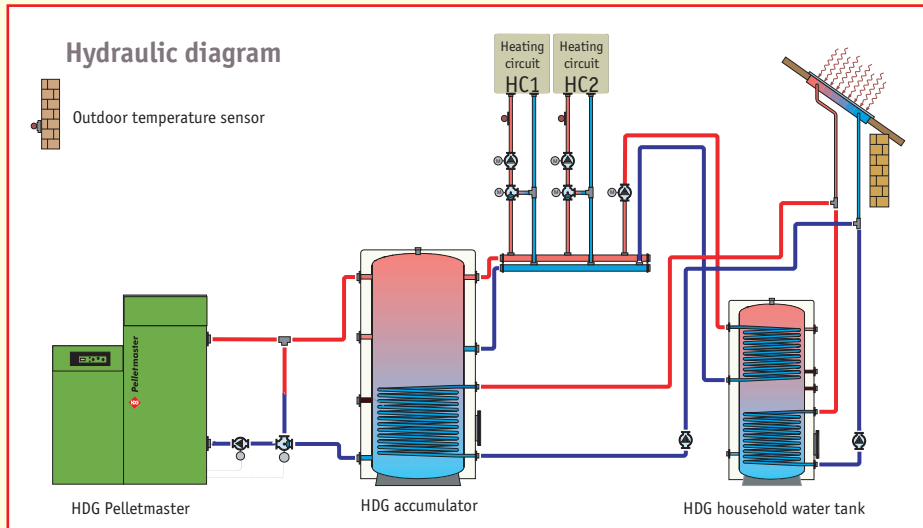

# HDG – Service and Quality

HDG boilers are high quality products: technologically advanced, rugged and durable.

The boilers are developed in Massing in Bavaria and manufactured by skilled competent employees. We pay special attention to high-quality materials and careful workmanship.

Our products, which have received many awards are known for their extremely long service life. Over 20,000 satisfied customers in nearly 25 years are proof of this.

Your local HDG distributor:



ENERGY

**Glas**

Mullins Mill  
Kells, Co. Kilkenny  
Ireland  
Tel: +353 (0)56 7728255  
or freephone  
1800 ENERGY (363749)  
info@glas.ie  
www.glas.ie



**HDG Bavaria**  
Heating systems for wood

**HDG Bavaria GmbH**  
Heating systems for wood  
Siemensstraße 22  
D-84323 Massing  
Phone +49(0)8724/897-0  
Fax +49(0)8724/8159  
info@hdg-bavaria.com  
www.hdg-bavaria.com



**HDG heating systems for wood**

**HDG wood chip, shaving and pellet boilers**



HDG wood chip, shaving  
and pellet fired boilers  
12 to 200 kW

**HDG log wood boiler**



HDG log wood boiler  
from 12 to 250 kW

**HDG pellet heating systems (This brochure)**



HDG pellet heating systems  
from 4.5 to 25 kW